

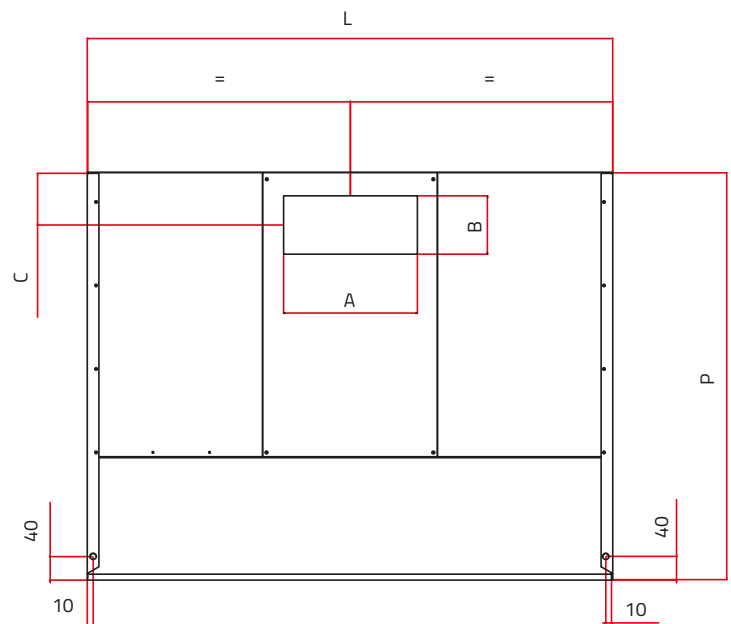

## CAPPE MINI SNACK con e senza elettroventilatore

*MINI SNACK WALL HOODS WITH OR WITHOUT EXTRACTOR FAN*

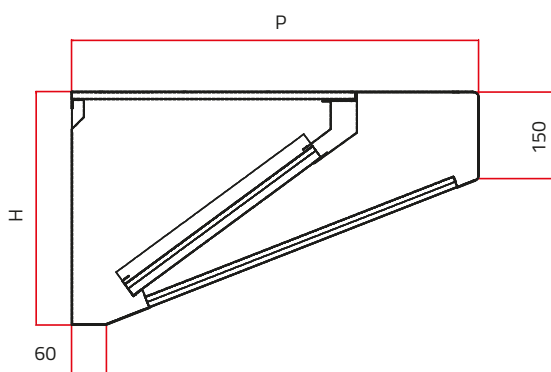

## LISTINO TECNICO Cappe snack a parete

### TECHNICAL PRICELIST Snack wall hoods

#### Serie 70

Modelli Models	304 €	Modelli Models	430 €	Dim. P x L x h mm	AxB mm	C mm	Filtri n° Filters n°	Peso Kg Weight Kg	Watt/ Amp	Volume MC/H*	LED
<b>GM 7/9</b>		<b>43GM 7/9</b>		700x900x400	150x150	150	2e	24			

#### CARATTERISTICHE COSTRUTTIVE:

Il particolare profilo la rende ideale per blocchi di cottura 60 posizionati a parete anche nei casi di soffitti bassi. Costruzione in AISI 304 o AISI 430. Esecuzioni speciali su richiesta.

#### In dotazione:

- Filtri a labirinto
- Scarico condensa in 1/2"

#### Note:

Per gli accessori vedi le pagine specifiche. Imballo pluriball con angolari in polistirolo compresi nel prezzo.

Modelli Models	304 €	Modelli Models	430 €	Dim. P x L x h mm	AxB mm	C mm	Filtri n° Filters n°	Peso Kg Weight Kg	Watt/ Amp	Volume MC/H*	LED
<b>GMM 7/9</b>		<b>43GMM 7/9</b>		700x900x400	100x230	90	2e	31	380/1,7	800	

#### CONSTRUCTION CHARACTERISTICS:

The special profile makes it ideal for cooking blocks 60 against a wall, even with low ceilings. Construction in AISI 304 or AISI 430. Special fabrication on request.

#### Supplied:

- Baffle filters
- Condensate draining cock 1/2"

#### Notes:

For the accessories please see the relative pages. Bubble wrap packaging with polystyrene corners included.

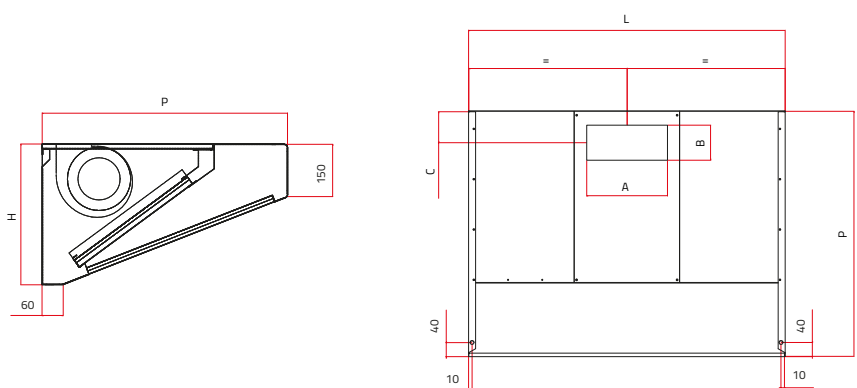

Modelli Models	304 €	Modelli Models	430 €	Dim. P x L x h mm	AxB mm	C mm	Filtri n° Filters n°	Peso Kg Weight Kg	Watt/ Amp	Volume MC/H*	LED
<b>GMS 7/9</b>		<b>43GMS 7/9</b>		700x900x400	100x230	90	2e	35	380/1,7	800	incl.

#### Filtri/filters : e (300x400)

